

BELT DRIVE TUBE AXIAL DUCT FANS

Designed for duct connected applications such as paint booth exhaust, air make-up fans, general exhaust, etc.



BTA For clean, dry air with a maximum temperature of 200°F (95°C).

- Adjustable motor base.
- Heavy duty pillow block ball bearings with high temperature grease.
- Extended lube lines with external grease fittings.
- TEFC motors are standard.
- Cast aluminum blades up to 48"; fans 54" & 60" have polypropylene reinforced fiberglass blades.
- Airfoil shaped belt tube for improved efficiency; motor, belts, drives and bearings are isolated from air stream.

WTA For moisture laden air with a maximum temperature of 200°F (95°C).

- Heavy duty pillow block bearings with moisture displacement collars.

HTA For clean, dry air with a maximum temperature of 375°F (190°C).

NOTE: To order WTA or HTA models, replace "BTA" with "WTA" or "HTA" in the table below.

DIMENSIONS

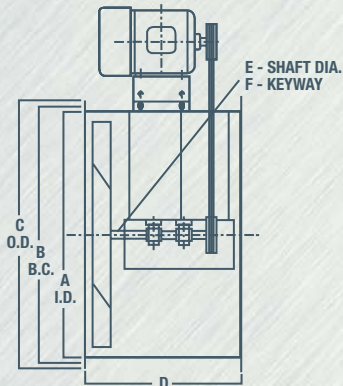

E - SHAFT DIA.
F - KEYWAY

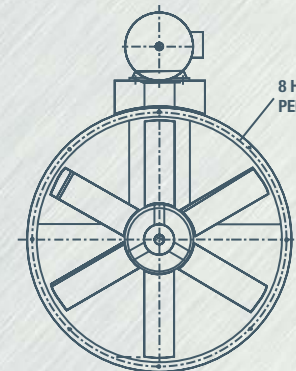

8 HOLES 7/16 dia.
PER FLANGE

FAN SIZE	A	B	C	D	E	F	WEIGHT (LBS)
12"	12"	14"	15 1/8"	17"	3/4"	3/16"	53
15"	15 3/8"	17"	18 3/8"	17"	3/4"	3/16"	62
18"	18 3/8"	20"	21 3/8"	21"	1"	1/4"	76
24"	24 3/8"	25 7/8"	27 3/8"	21"	1 3/16"	1/4"	132
30"	30 3/8"	32 3/8"	33 3/8"	21"	1 7/16"	3/8"	174
34"	34 3/8"	36 3/8"	37 3/8"	27"	1 7/16"	3/8"	225
36"	36 3/8"	38 3/8"	39 3/8"	27"	1 7/16"	3/8"	239
42"	42 3/8"	44 3/8"	45 3/8"	32"	1 7/16"	3/8"	326
48"	48 3/8"	50 3/8"	51 3/8"	32"	1 15/16"	1/2"	420
54"	54 3/8"	56 3/8"	57 3/8"	40"	1 15/16"	1/2"	552
60"	60 3/8"	62 3/8"	63 3/8"	40"	1 15/16"	1/2"	601

BLADE DIAMETER	MODEL #		RPM	H.P.	dBA @ 5 ft.	CFM @ STATIC PRESSURE										
	SINGLE PHASE	THREE PHASE				0"	1/8"	1/4"	3/8"	1/2"	3/4"	1"	1 1/4"	1 1/2"		
	12"	BTA12T10033				BTA12T30033*	2535	1/3	60	2100	2020	1950	1890	1800	-	-
12"	BTA12T10050	BTA12T30050*	2865	0.5	64	2370	2330	2240	2190	2120	1940	1590	-	-	-	-
	BTA12T10075	BTA12T30075*	3290	0.75+	70	2720	2660	2610	2550	2500	2380	2200	1890	-	-	-
	BTA12T10100	BTA12T30100*	3645	1+	74	3020	2970	2910	2860	2810	2720	2600	2420	2150	-	-
15"	BTA15T10033	BTA15T30033*	1850	1/3	61	2780	2640	2480	2290	2050	-	-	-	-	-	-
	BTA15T10050	BTA15T30050*	2105	0.5	66	3170	3040	2910	2710	2580	2110	-	-	-	-	-
	BTA15T10075	BTA15T30075*	2405	0.8	72	3620	3510	3410	3350	3150	2810	2380	-	-	-	-
15"	BTA15T10100	BTA15T30100*	2660	1.0	75	4000	3910	3810	3690	3590	3230	2990	2570	1140	-	-
	BTA15T10150	BTA15T30150*	3040	1.5+	81	4580	4490	4390	4330	4220	3940	3780	3480	3150	-	-
	BTA18T10050	BTA18T30050*	1556	0.5	58	4110	3930	3760	3540	3260	1760	-	-	-	-	-
18"	BTA18T10075	BTA18T30075*	1785	0.8	61	4680	4530	4380	4210	4020	3440	1930	-	-	-	-
	BTA18T10100	BTA18T30100*	1920	1.0	63	5040	4890	4750	4610	4440	4010	3290	1800	1210	-	-
	BTA18T10150	BTA18T30150*	2255	1.5	68	5920	5790	5670	5550	5430	5140	4770	4210	3410	-	-
18"	BTA18T10200	BTA18T30200*	2510	2.0	72	6590	6490	6360	6280	6150	5930	5650	5260	4790	-	-
	BTA24T10075	BTA24T30075*	1180	0.8	58	6750	6325	5880	5360	4700	2180	-	-	-	-	-
	BTA24T10100	BTA24T30100*	1295	1.0	61	7400	7020	6620	6180	5690	4690	1980	-	-	-	-
24"	BTA24T10150	BTA24T30150*	1475	1.5	64	8430	8090	7680	7390	7000	6010	4320	3110	-	-	-
	BTA24T10200	BTA24T30200*	1620	2.0	67	9260	8960	8640	8330	7990	7220	6190	6080	4130	-	-
	BTA24T10300	BTA24T30300*	1890	3.0	72	10800	10670	10290	10060	9730	8890	8480	12820	10810	-	-
30"	BTA30T10100	BTA30T30100*	965	1.0	58	10800	10050	9190	8100	6610	2620	-	-	-	-	-
	BTA30T10150	BTA30T30150*	1095	1.5	61	12320	11650	11000	10130	9140	5210	2770	-	-	-	-
	BTA30T10200	BTA30T30200*	1225	2.0	64	13810	13170	12550	11930	11100	9120	5260	5320	-	-	-
30"	BTA30T10300	BTA30T30300*	1380	3.0	67	15490	14910	14540	13930	13270	11790	9830	10860	4130	-	-
	BTA30T10500	BTA30T30500*	1635	5.0	73	18410	17850	17540	17160	16590	15470	14280	17820	10810	-	-
	BTA34T10150	BTA34T30150*	895	1.5	61	15100	14000	12880	11300	9420	4800	-	-	-	-	-
34"	BTA34T10200	BTA34T30200*	960	2.0	62	16200	15180	14060	12880	11300	5280	3450	-	-	-	-
	BTA34T10300	BTA34T30300*	1125	3.0	66	19000	18120	17220	16270	15200	12350	8070	5320	-	-	-
	BTA34T10500	BTA34T30500*	1320	5.0	72	22300	21550	20770	20130	19060	17220	14900	10860	8310	-	-
34"	BTA34T10750	BTA34T30750*	1520	7.5	75	25700	25010	24350	23730	23040	21610	19830	17820	14760	-	-
	BTA36T10200	BTA36T30200*	910	2.0	63	17820	16650	15420	13980	12190	7310	-	-	-	-	-
	BTA36T10300	BTA36T30300*	1045	3.0	66	20490	19220	18410	17550	16020	12050	8270	5190	-	-	-
36"	BTA36T10500	BTA36T30500*	1245	5.0	71	24410	23610	22650	21780	20070	18650	15890	11620	9140	-	-
	BTA36T10750	BTA36T30750*	1425	7.5	75	27930	27110	26380	27790	24830	23230	21220	18850	15290	-	-
	BTA42T10200	BTA42T30200*	770	2.0	60	20690	19920	17310	15080	11320	-	-	-	-	-	-
42"	BTA42T10300	BTA42T30300*	895	3.0	64	24120	22840	21430	19620	17680	10290	-	-	-	-	-
	BTA42T10500	BTA42T30500*	1005	5.0	67	27070	25980	24640	23230	21810	17750	10780	6820	-	-	-
	BTA42T10750	BTA42T30750*	1205	7.5	72	32420	31520	30640	29530	28290	25760	22510	16620	12290	-	-
42"	BTA42T11000	BTA42T31000*	1335	10.0	75	35910	35170	34340	33410	32390	30120	27730	24640	19620	-	-
	BTA48T10300	BTA48T30300*	745	3.0	63	25790	24330	22450	20510	17780	-	-	-	-	-	-
	BTA48T10500	BTA48T30500*	885	5.0	67	30710	29440	27810	26370	24690	20570	14310	-	-	-	-
48"	BTA48T10750	BTA48T30750*	1005	7.5	71	34830	33850	32310	31080	29810	26690	22390	17120	-	-	-
	BTA48T11000	BTA48T31000*	1105	10.0	73	38300	37270	36210	34760	33670	31090	28120	23710	18930	-	-
	-	BTA48T31500*	1265	15.0	76	43870	42900	42230	40860	39850	37760	35620	32760	29450	-	-
54"	BTA54T10500	BTA54T30500*	710	5.0	69	39490	37130	34510	31680	28260	-	-	-	-	-	-
	BTA54T10750	BTA54T30750*	810	7.5	72	45020	42890	40760	38660	35890	29810	20380	-	-	-	-
	BTA54T11000	BTA54T31000*	905	10.0	75	50330	48450	46590	44640	42420	37520	31620	22910	15230	-	-
60"	-	BTA54T31500*	1025	15.0	78	57010	55520	53850	52110	50170	46260	42140	36610	28880	-	-
	BTA60T10750	BTA60T30750*	690	7.5	68	54300	51240	48620	45760	41310	27620	18390	-	-	-	-
	BTA60T11000	BTA60T31000*	755	10.0	70	59420	56770	54150	51490	48410	39330	26420	17510	-	-	-
60"	-	BTA60T31500*	870	15.0	73	68490	66320	63840	61710	59300	53450	45310	32880	25690	-	-
	-	BTA60T32000*	955	20.0	76	75110	73090	70670	68880	67010	62340	55910	47640	35870	-	-

For three phase motors, substitute "*" with "M" for 208-230/460 volt or "P" for 575 volt + Motor RPM is 3450. All others are 1750.

dBA ratings shown are measured at 0" static pressure and should be used as a guideline only

OPTIONS & ACCESSORIES

For a complete listing of all available options and accessories available for this fan and ordering guidelines, see page 22. When ordering, replace "T" (in chart above) with ALL letters of the options & accessories required, as shown on page 22. Note: Options must be requested at time of order, as they cannot be added later.

DDA - DIRECT DRIVE TUBE AXIAL DUCT FANS

Minimum maintenance. Maximum efficiency.

For clean, dry air with a maximum temperature of 100°F (40°C).

FEATURES

- Cast aluminum blades are standard.
- TEFC motors are standard.



BLADE DIAMETER	MODEL #		RPM	H.P.	dBA @ 5 ft.	CFM @ STATIC PRESSURE					
	SINGLE PHASE	THREE PHASE				0"	1/4"	1/2"	3/4"	1"	1 1/4"
	12"	DDA12T10033B				DDA12T30033B*	1750	1/3	49	1450	1230
12"	DDA12T10100A	DDA12T30100A*	3450	1.0	72	2860	2740	2640	2530	2410	2140
15"	DDA15T10033B	DDA15T30033B*	1750	1/3	65	2630	2320	1840	-	-	-
18"	DDA18T10033C	DDA18T30033C*	1140	1/3	49	2990	2450	845	-	-	-
18"	DDA18T10075B	DDA18T30075B*	1750	3/4	61	4590	4280	3910	3260	1750	-
24"	DDA24T10050C	DDA24T30050C*	1140	0.5	52	4990	4180	2920	1210	-	-
	DDA24T10100C	DDA24T30100C*	1140	1.0	57	6520	5630	4380	1920	813	-
	DDA24T10150C	DDA24T30150C*	1140	1.5	61	8710	7630	6020	2380	720	-
	DDA24T10150B	DDA24T30150B*	1750	1.5	65	7660	7160	6620	5980	5170	4020
	DDA24T10200B	DDA24T30200B*	1750	2.0	66	9210	8660	8090	7470	6660	5540
	DDA24T10300B	DDA24T30300B*	1750	3.0	71	11500	10900	10200	9490	8680	7540
30"	DDA30T10100C	DDA30T30100C*	1140	1.0	57	8680	7480	6000	3630	1550	-
	DDA30T10150C	DDA30T30150C*	1140	1.5	61	11800	10600	8950	6070	3070	-
	-	DDA30T30200C*	1140	2.0	62	12780	11490	9850	7320	3620	-
	-	DDA30T30300C*	1140	3.0	68	16400	14700	12700	6840	4120	-
	DDA30T10300B	DDA30T30300B*	1750	3.0	69	13300	12550	11700	11000	9980	8830
	DDA30T10500B	DDA30T30500B*	1750	5.0	73	18200	17350	16550	15200	14600	13880
30"	DDA30T10750B	DDA30T30750B*	1750	7.5	77	22600	21980	20650	19030	18300	17550
34"	-	DDA34T30200C*	1140	2.0	64	15300	13800	12000	10490	6070	3440
	-	DDA34T30300C*	1140	3.0	67	19300	17700	15600	12900	8620	6110
	-	DDA34T30500C*	1140	5.0	70	22500	20550	18300	13100	10200	6860
	DDA34T10500B	DDA34T30500B*	1750	5.0	76	18700	17820	16800	15700	14600	13660
	DDA34T10750B	DDA34T30750B*	1750	7.5	76	23500	22600	21500	20400	19300	18160
	-	DDA34T31000B*	1750	10.0	78	27800	26750	25500	24250	23300	22150
34"	-	DDA34T31500B*	1750	15.0	81	31300	30300	29100	28250	26600	25130
36"	-	DDA36T30200C*	1140	2.0	66	14000	12400	10600	8390	5530	-
	-	DDA36T30300C*	1140	3.0	67	19400	17550	15600	13100	8980	6450
	-	DDA36T30500C*	1140	5.0	68	23600	22050	19700	16850	11700	9220
	DDA36T10500B	DDA36T30500B*	1750	5.0	70	16200	15200	14200	12800	12200	11050
	-	DDA36T30750C*	1140	7.5	72	26100	23800	21600	18350	12900	9730
	DDA36T10750B	DDA36T30750B*	1750	7.5	78	21500	20400	19400	18350	17100	15850
36"	-	DDA36T31000B*	1750	10.0	79	29700	28550	27300	26150	24900	23700
-	DDA36T31500B*	1750	15.0	81	34320	32960	31970	30680	29280	28030	
42"	-	DDA42T30200D*	860	2.0	61	19200	16300	12400	6720	-	-
	-	DDA42T30300D*	860	3.0	63	23210	20230	16280	8980	3940	-
	-	DDA42T30500D*	860	5.0	66	28900	25600	20800	11100	6290	-
	-	DDA42T30500C*	1140	5.0	68	25500	23550	21100	18300	14200	10100
	-	DDA42T30750C*	1140	7.5	70	30690	28750	26190	23350	19410	12780
	-	DDA42T31000C*	1140	10.0	73	38300	35700	33100	29450	23000	15400
42"	-	DDA42T31000B*	1750	10^	76	26700	25200	23750	22380	21100	19570
-	DDA42T31500B*	1750	15^	80	39100	38080	36700	34640	33500	32040	
-	DDA42T32000B*	1750	20^	82	43300	42280	40860	39170	37600	36140	
48"	-	DDA48T30500D*	860	5.0	66	29820	26940	23790	12790	12790	6740
	-	DDA48T30750D*	860	7.5	68	35700	32450	28600	16800	16800	8270
	-	DDA48T31000C*	1140	10.0	74	39500	37400	35000	29800	29800	26050
	-	DDA48T31500C*	1140	15.0	76	47300	45050	42300	36200	36200	33490
48"	-	DDA48T32000C*	1140	20.0	79	53900	51450	48400	42300	42300	37120

DIMENSIONS

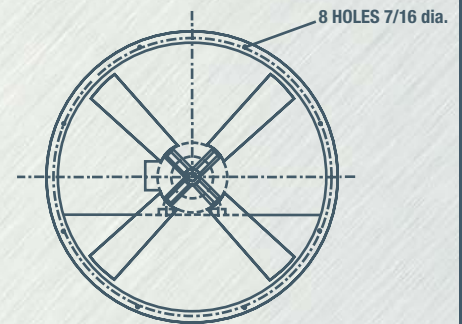
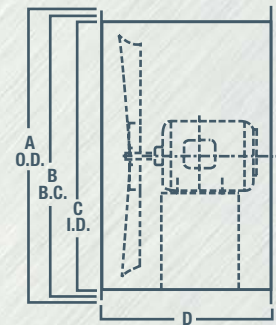

FAN SIZE	A	B	C	D	WEIGHT (LBS)
12"	15 1/8"	14"	12"	17"	37
15"	17 7/8"	17"	15 3/8"	17"	42
18"	20 7/8"	20"	18 3/8"	21"	55
24"	27 3/8"	25 7/8"	24 3/8"	21"	102
30"	33 3/8"	32 3/8"	30 3/8"	21"	138
34"	37 3/8"	36 3/8"	34 3/8"	27"	169
36"	39 3/8"	38 3/8"	36 3/8"	27"	181
42"	45 3/8"	44 3/8"	42 3/8"	32"~	225
48"	51 3/8"	50 3/8"	48 3/8"	32"~	308

For three phase motors, substitute "*" with "M" for 208-230/460 volt or "P" for 575 volt

Fan blades tested in accordance with AMCA standard 210, figure 12

dBA ratings shown are measured at 0" static pressure and should be used as a guideline only

^ Electro anti-static glass reinforced nylon blade, all others are cast aluminum



For a complete listing of all available options and accessories available for this fan and ordering guidelines, see page 22. When ordering, replace "T" (in chart above) with ALL letters of the options & accessories required, as shown on page 22. Note: Options must be requested at time of order, as they cannot be added later.

REFERENCE	ITEM	DESCRIPTION	SPECIAL ORDERING GUIDELINES
A	Disconnect Switch (not shown) (Accessory)	See page 10 for more information.	To order installed, add letter to part number. Also available as an accessory ordered separately.
B	Inlet Guard (Accessory)	<ul style="list-style-type: none"> Spiral plated OSHA guard. Fits intake or exhaust. Can be used in conjunction with companion ring. 	To order installed, add letter to part number. Also available as an accessory ordered separately.
J	Outlet Guard (Accessory)		
C	Companion Rings (Accessory)	<ul style="list-style-type: none"> 1/4" plate angle ring. Used to attach guards or ducts to tube axial fans. 	To order installed, add letter to part number. Also available as an accessory ordered separately.
D	Vertical Support Clips (Accessory)	<ul style="list-style-type: none"> 1/4" plate vertical support clips are welded onto fan. Four clips per end. 	Must be requested at time of order.
K	Horizontal Support Clips (Accessory)	<ul style="list-style-type: none"> 1/4" plate horizontal support clips. Bolts to the vertical support clips welded onto the fan. Two clips per end. 	Must be requested at time of order. Must be used with vertical clips (D). Eg) For a BTA18T10050 with horizontal clips & belt guard, use BTA18DKG10050. Note: "D" for vertical clips must be indicated as well as the "K" for horizontal clips.
E	Support Legs (Option)	<ul style="list-style-type: none"> Heavy duty support legs are welded to the fan. Suitable for mounting tube axial to the floor. 4" Standard. 16" available. Consult factory. Sold in pairs. 	Must be requested at time of order.
F	Motor & Belt Covers (Accessory)	<ul style="list-style-type: none"> 18 gauge galvanized steel. Acts as both motor and belt cover. 3/4" expanded metal screen allows motor heat to escape. Bolts to motor mount. 	For HTA/BTA/WTA Fans only. To order installed, add letter to part number. Also available as an accessory ordered separately.
G	Belt Guard (Accessory)	<ul style="list-style-type: none"> Belt and guards protect the belt and drives. 18 gauge galvanized steel. 	For HTA/BTA/WTA Fans only. Not required with motor cover. To order installed, add letter to part number. Also available as an accessory ordered separately.
H	Inspection Door (Option)	<ul style="list-style-type: none"> 10" x 12" inspection door. Hinged and bolted. Air dry finish. Can be installed in location specified by customer. 	Must be requested at time of order.
I	Specials (not shown)	Can include: <ul style="list-style-type: none"> Explosion Proof Motors Steel Fan Blades Optional Coating 	Must be requested at time of order.

ORDERING EXAMPLES:

If ordering a BTA18T10050 with support legs (E) and an inspection door (H), use **BTA18EH10050**.

If ordering a BTA18T10050 with horizontal clips & belt guard, use **BTA18DKG10050**.



MC - GUARDS



CR - COMPANION RING



SCV - VERTICAL SUPPORT CLIPS



SCH - HORIZONTAL SUPPORT CLIP



SPL - SUPPORT LEGS



MCVR - MOTOR & BELT COVER



BLG - BELT GUARD



ID - INSPECTION DOOR

FAN SIZE	ACCESSORIES ASSEMBLED BY CUSTOMER			OPTIONS INSTALLED WELDED TO TUBE		
	COMPANION RING	GUARD	HORIZONTAL CLIP	SUPPORT LEG	VERTICAL CLIP	INSPECTION DOOR
12"	CR12P	MC12G	SCH12-60 (Must order vertical clip option to use horizontal clip accessory)	SPL12	SCV12-60	ID12
15"	CR15P	MC15G		SPL15		ID15
18"	CR18P	MC18G		SPL18		ID18
24"	CR24P	MC24G		SPL24		ID24
30"	CR30P	MC30G		SPL30		ID30
34"	CR34P	MC34G		SPL34		ID34
36"	CR36P	MC36G		SPL36		ID36
42"	CR42P	MC42G		SPL42		ID42
48"	CR48P	MC48G		SPL48		ID48
54"	CR54P	MC54G		SPL54		ID54
60"	CR60P	MC60G		SPL60		ID60

ACCESSORIES ASSEMBLED BY CUSTOMER		
FRAME SIZE	MOTOR COVER	BELT GUARD
48-145T	MCVR1	BLGD1
182T-184T	MCVR2	BLGD2
213T-256T	MCVR3	BLGD3
284 AND UP	MCVR4	BLGD4